

Summary: Displacements - Pressures - Speeds

	Type	Displacement	Max. Pressure	Min speed	Max speed
XV-0P	XV-0P/0.17	0.16 cm ³ /rev	260 bar	700 rpm	9000 rpm
	XV-0P/0.25	0.24 cm ³ /rev	260 bar	700 rpm	9000 rpm
	XV-0P/0.45	0.45 cm ³ /rev	280 bar	700 rpm	9000 rpm
	XV-0P/0.57	0.56 cm ³ /rev	280 bar	700 rpm	9000 rpm
	XV-0P/0.76	0.75 cm ³ /rev	280 bar	700 rpm	9000 rpm
	XV-0P/0.98	0.92 cm ³ /rev	280 bar	700 rpm	6000 rpm
	XV-0P/1.27	1.26 cm ³ /rev	280 bar	700 rpm	6000 rpm
	XV-0P/1.52	1.48 cm ³ /rev	280 bar	700 rpm	6000 rpm
	XV-0P/2.30	2.28 cm ³ /rev	210 bar	700 rpm	5000 rpm
XV-1P	XV-1P/0.9	0.91 cm ³ /rev	280 bar	700 rpm	6000 rpm
	XV-1P/1.2	1.17 cm ³ /rev	290 bar	700 rpm	6000 rpm
	XV-1P/1.7	1.56 cm ³ /rev	290 bar	700 rpm	6000 rpm
	XV-1P/2.2	2.08 cm ³ /rev	290 bar	700 rpm	6000 rpm
	XV-1P/2.6	2.60 cm ³ /rev	300 bar	700 rpm	6000 rpm
	XV-1P/3.2	3.12 cm ³ /rev	300 bar	700 rpm	6000 rpm
	XV-1P/3.8	3.64 cm ³ /rev	300 bar	700 rpm	6000 rpm
	XV-1P/4.3	4.16 cm ³ /rev	300 bar	700 rpm	6000 rpm
	XV-1P/4.9	4.94 cm ³ /rev	300 bar	700 rpm	6000 rpm
	XV-1P/5.9	5.85 cm ³ /rev	300 bar	700 rpm	5000 rpm
	XV-1P/6.5	6.50 cm ³ /rev	300 bar	700 rpm	5000 rpm
	XV-1P/7.8	7.54 cm ³ /rev	260 bar	700 rpm	5000 rpm
	XV-1P/9.8	9.88 cm ³ /rev	230 bar	700 rpm	4000 rpm
XV-2P	XV-2P/4	4.2 cm ³ /rev	300 bar	700 rpm	3500 rpm
	XV-2P/6	6.0 cm ³ /rev	300 bar	700 rpm	3500 rpm
	XV-2P/9	8.4 cm ³ /rev	300 bar	700 rpm	3500 rpm
	XV-2P/11	10.8 cm ³ /rev	300 bar	700 rpm	3500 rpm
	XV-2P/14	14.4 cm ³ /rev	290 bar	700 rpm	3500 rpm
	XV-2P/17	16.8 cm ³ /rev	270 bar	700 rpm	3500 rpm
	XV-2P/19	19.2 cm ³ /rev	250 bar	700 rpm	3000 rpm
	XV-2P/22	22.8 cm ³ /rev	240 bar	700 rpm	3000 rpm
	XV-2P/26	26.2 cm ³ /rev	210 bar	700 rpm	3000 rpm
	XV-2P/30	30.0 cm ³ /rev	200 bar	700 rpm	2500 rpm
	XV-2P/34	34.2 cm ³ /rev	190 bar	700 rpm	2500 rpm
XV-3P	XV-3P/40	39.6 cm ³ /rev	180 bar	700 rpm	2000 rpm
	XV-3P/15	14.89 cm ³ /rev	320 bar	700 rpm	3000 rpm
	XV-3P/18	17.37 cm ³ /rev	320 bar	700 rpm	3000 rpm
	XV-3P/21	21.10 cm ³ /rev	300 bar	700 rpm	3000 rpm
	XV-3P/27	26.97 cm ³ /rev	270 bar	700 rpm	3000 rpm
	XV-3P/32	32.27 cm ³ /rev	270 bar	700 rpm	3000 rpm
	XV-3P/38	38.47 cm ³ /rev	270 bar	700 rpm	2800 rpm
	XV-3P/43	43.44 cm ³ /rev	250 bar	700 rpm	2800 rpm
	XV-3P/47	47.16 cm ³ /rev	250 bar	700 rpm	2800 rpm
	XV-3P/51	50.88 cm ³ /rev	250 bar	700 rpm	2800 rpm
	XV-3P/54	54.60 cm ³ /rev	250 bar	700 rpm	2300 rpm
	XV-3P/61	60.81 cm ³ /rev	220 bar	700 rpm	2300 rpm
	XV-3P/64	64.53 cm ³ /rev	220 bar	700 rpm	2300 rpm
	XV-3P/70	70.74 cm ³ /rev	210 bar	700 rpm	2300 rpm
	XV-3P/74	74.46 cm ³ /rev	190 bar	700 rpm	2300 rpm
XV-3P/90	86.87 cm ³ /rev	160 bar	700 rpm	2300 rpm	

General technical data

Type of fluid to be used	Mineral-based hydraulic oil HLP HV (D IN 51524)
Minimum operating viscosity	10 mm ² /s
Maximum operating viscosity	100 mm ² /s
Maximum admissible viscosity at start-up	1500 mm ² /s
Recommended viscosity	20 mm ² /s - 100 mm ² /s
Ambient temperature	-20 °C - 60°C
Fluid operating temperature	-15°C - 80°C
Recommended fluid operating temperature	30°C - 50° C
For temperatures above 120°C	Request FKM seals (V iton)
Max. inlet fluid suction pressure (IN)	0.02-0.08 bars
Max. inlet fluid pressure (IN)	0.3 - 0.5 bars (for higher pressures consult the manufacturer)
Inlet fluid filtering (IN)	30 - 60 Microns
Outlet fluid filtering (OUT)	10 - 25 Microns
Max. inlet fluid speed (IN)	0.5 - 1.5 m/s
Max. outlet fluid speed (OUT)	3.0 - 5.5m/s
Use of water-glycol (HF-C)	max n. of revolutions 1100 rpm; max pressure 170 bars

Flow rate tables

TYPE	cm3/ rev	Flow rate l/min	rpm														Flow rate l/min		
			700	1000	1500	2000	2500	3000	3500	4000	4500	5000	5500	6000	7000	8000		9000	
XV 0P/0.17	0,16	Flow rate l/min	0,106	0,152	0,228	0,304	0,380	0,456	0,532	0,608	0,684	0,760	0,836	0,912	1,064	1,216	1,368	Flow rate l/min	
XV 0P/0.25	0,24		0,160	0,228	0,342	0,456	0,570	0,684	0,798	0,912	1,026	1,140	1,254	1,368	1,596	1,824	2,052		
XV 0P/0.45	0,45		0,299	0,428	0,641	0,855	1,069	1,283	1,496	1,710	1,924	2,138	2,351	2,565	2,993	3,420	3,848		
XV 0P/0.57	0,56		0,372	0,532	0,798	1,064	1,330	1,596	1,862	2,128	2,394	2,660	2,926	3,192	3,724	4,256	4,788		
XV 0P/0.76	0,75		0,499	0,713	1,069	1,425	1,781	2,138	2,494	2,850	3,206	3,563	3,919	4,275	4,988	5,700	6,413		
XV 0P/0.98	0,92		0,612	0,874	1,311	1,748	2,185	2,622	3,059	3,496	3,933	4,370	4,807	5,244					
XV 0P/1.27	1,26		0,838	1,197	1,796	2,394	2,993	3,591	4,190	4,788	5,387	5,985	6,584	7,182					
XV 0P/1.52	1,48		0,984	1,406	2,109	2,812	3,515	4,218	4,921	5,624	6,327	7,030	7,733	8,436					
XV 0P/2.30	2,28		1,516	2,166	3,249	4,332	5,415	6,498	7,581	8,664	9,747	10,830							

TYPE	cm3/ rev	Flow rate l/min	rpm											Flow rate l/min	
			700	1000	1500	2000	2500	3000	3500	4000	4500	5000	5500		6000
XV 1P/0.9	0,91	Flow rate l/min	0,630	0,900	1,350	1,800	2,250	2,700	3,150	3,600	4,050	4,500	4,950	5,400	Flow rate l/min
XV 1P/1.2	1,17		0,840	1,200	1,800	2,400	3,000	3,600	4,200	4,800	5,400	6,000	6,600	7,200	
XV 1P/1.7	1,56		1,190	1,700	2,550	3,400	4,250	5,100	5,950	6,800	7,650	8,500	9,350	10,200	
XV 1P/2.2	2,08		1,540	2,200	3,300	4,400	5,500	6,600	7,700	8,800	9,900	11,000	12,100	13,200	
XV 1P/2.6	2,6		1,820	2,600	3,900	5,200	6,500	7,800	9,100	10,400	11,700	13,000	14,300	15,600	
XV 1P/3.2	3,12		2,240	3,200	4,800	6,400	8,000	9,600	11,200	12,800	14,400	16,000	17,600	19,200	
XV 1P/3.8	3,64		2,660	3,800	5,700	7,600	9,500	11,400	13,300	15,200	17,100	19,000	20,900	22,800	
XV 1P/4.3	4,16		3,010	4,300	6,450	8,600	10,750	12,900	15,050	17,200	19,350	21,500	23,650	25,800	
XV 1P/4.9	4,94		3,430	4,900	7,350	9,800	12,250	14,700	17,150	19,600	22,050	24,500	26,950	29,400	
XV 1P/5.9	5,85		4,130	5,900	8,850	11,800	14,750	17,700	20,650	23,600	26,550	29,500			
XV 1P/6.5	6,5		4,550	6,500	9,750	13,000	16,250	19,500	22,750	26,000	29,250	32,500			
XV 1P/7.8	7,54		5,460	7,800	11,700	15,600	19,500	23,400	27,300	31,200	35,100	39,000			
XV 1P/9.8	9,88		6,860	9,800	14,700	19,600	24,500	29,400	34,300	39,200					

TORQUES ALLOWED ON SHAFT:

FORMULA FOR EVALUATING SHAFT		SHAFT [IDENTIFIER] - CODE - DESCRIPTION	T.2 [Nm]
$T.2 \leq \frac{v_i \times \Delta p}{20 \times \pi \times \eta m}$ <p>T.2 = max. torque allowed by shaft [Nm]</p>	XV-0P	[A] - CI001 - Parallel ø 7 - M 7x1 - key thk sp.2	2
		[B] - CF001 - Milled shank ø 7 - sp. 5	9,2
		[F] - CF005 - Milled shank ø 7 - sp.4,5 L = 9	8
	XV-1P	[A] - CI001 - Parallel ø12 - M10x1 - key thk. 3	25,8
		[B] - CI002 - Parallel ø12.7 - key thk. 3.2 (SAE)	32,8
		[C] - CF001 - Milled shank ø10 - thk.5 ("BH" Standard German)	13,8
		[D] - CF002 - Milled shank ø10 - thk.5	13,8
		[E] - CF003 - Milled shank ø11 - thk.6.63 (SAE)	25,8
		[F] - CO001 - Tapered 1:8 - ø10 - M7x1 - key thk.2.4	43
		[G] - CO002 - Tapered 1:8 - ø14 - M10x1 - key thk.3	119,8
		[I] - CO004 - Tapered 1:8 - ø12.7 - 5/16" 24UNF-2A - key thk.3.2 (SAE)	90,4
		[J] - SCF04 - Splined ø11.7 - z=6, H=17.5, m=1.6, DIN 5482 12x9	22,6
		[K] - SCF05 - Splined ø12.344, z=9, H=19, SAE J498 9T 20/40DB	32,2
		[L] - SCF02 - Splined ø11.9, z=15, H=17.5, m=0.75	42,8
		[O] - CO002+HK - Tapered 1:8 - ø14 - M10x1, HK 14-12, key thk.3	119,8
		[P] - CI001+HK - Parallel ø12 - M10x1 with bearing HK 14-12 - key thk.3	25,8
		[Q] - SCF01 - Splined ø11.9, z=15, H=9, m=0.75	42,8
	[R] - SCF03 - Splined ø11.9, z=15, H=9, m=0.75	42,8	
	XV-2P	[A] - CI001 - Parallel ø15 - M6x1 - key thk.4	44.1
		[B] - CI002 - Parallel ø15.875 - 1/4"28-UNF key thk.4 (SAE A)	67.5
		[C] - CF001 - Miled shank ø15 - thk.8 ("BH" Standard German)	60.5
		[E] - CO001 - Tapered 1:8 - ø17,4 - M12x1,5 - key thk.4	233.2
		[F] - CO002 - Tapered 1:5 - ø17,4 - M12x1,5 - key thk.3	233.2
		[G] - SCF02 - Splined ø16,5 - z=9, H=13, m=1.6 DIN 5482 17x14	86.1
		[H] - SCF03 - Splined ø16.5 - z=9, H=18,8, m=1,6 DIN 5482 17x14	86.1
		[I] - SCF04 - Splined ø15.456 z=9, H=22.5, SAE J498 9T 16/32DP	67.1
		[K] - SCF05 - Splined ø16.5 z=9 H=8,1 m=1.6 DIN 5482 17x14	86.2
[L] - SCF01 - Splined ø16.5 z=9 H=9,2 m=1.6 DIN 5482 17x14		86.2	
[M] - CO001 - Tapered 1:8 - ø17,4 - M12x1,5 - key thk.3,2		233.2	
XV-3P	[A] - CO001 - Tapered 1:8 - ø22 - M14x1.5 - key thk.4	482	
	[B] - CI001 - Parallel ø20 - M8 - key thk.5	181	
	[C] - SCF03 - Splined ø21.5, z=13, H=25, m=1,6	223	
	[H] - CI004 - Parallel ø22.225- 1/4"28-UNF key thk.6.35 (SAE B)	180	
	[I] - SCF04 - Splined ø21.8059, z=13, H=25, SAE J498 9T 16/32DP	264	

NOTES:

For assemblies with a coupling, you should choose one as balanced as possible in order to reduce the vibrations and dynamic stresses to which the pump shaft may be subject.

Always make sure that the torque applied is less than or equal to the admissible torque of the shaft.

Do not apply a direct axial or radial load on the pump shaft; if necessary, use suitable supports.

Always use well-filtered oils containing no water or other emulsifying substance.

Never run the pump with oil and air solutions.

For pumps with outlets on the flange, it is recommended not to exceed a flow rate of

4 l/min	XV-0P
20 l/min.	XV-1P
35 l/min	XV-2P

Useful calculation formulas

SYMBOL, UNIT OF MEASUREMENT, DESCRIPTION		
qv	l/min	Flow rate
vi	cm ³ /rev.	Displacement (volume of oil displaced per complete revolution of the shaft)
n	rpm	Shaft rotation speed
p1	bar	inlet pressure
p2	bar	outlet pressure
Δp	bar	Δp=p2 - p1 difference between outlet (OUT) and inlet (IN) pressure
Ph	kW	Hydraulic power delivered
Pm	kW	Mechanical power absorbed
T	Nm	Torque absorbed by shaft
ηv	-	0.91 – 0.96 volumetric efficiency (volumetric ratio between operation under load and loadless operation)
ηm	-	0.85 – 0.90 mechanical efficiency
ηt	-	ηt = ηv x ηm total efficiency

Basic Formulas	Derived Formulas	
$qv = \frac{vi \times n}{1000} \times \eta v$	$vi = \frac{qv \times 1000}{n \times \eta v}$	$n = \frac{qv \times 1000}{vi \times \eta v}$
$T = \frac{vi \times \Delta p}{20 \times \pi \times \eta m}$	$vi = \frac{T \times 20 \times \pi \times \eta m}{\Delta p}$	$\Delta p = \frac{T \times 20 \times \pi \times \eta m}{vi}$
$Ph = \frac{qv \times \Delta p}{600}$	$qv = \frac{Ph \times 600}{\Delta p}$	$\Delta p = \frac{Ph \times 600}{qv}$
$Pm = \frac{vi \times \Delta p \times n}{600000 \times \eta m}$	$vi = \frac{Pm \times 600000 \times \eta m}{\Delta p \times n}$	$\Delta p = \frac{600000 \times \eta m}{vi \times n}$

Constructive features

PART	MATERIAL	MECHANICAL FEATURES
PUMP BODY	Extruded alloy Series 7000, heat treated and anodised	Rp = 345 N/mm ² (Yield strength) Rm = 382 N/mm ² (Breaking strength)
FLANGE AND COVER	Die-cast aluminium alloy with excellent mechanical features, heat treated and anodised	Rp = 310÷350 N/mm ² (Yield strength) Rm = 350÷400 N/mm ² (Breaking strength)
GEAR BUSH BEARINGS	Special heat-treated tin alloy with excellent mechanical features and high anti-friction capacity. Self-lubricating bushes DU	Rp = 350 N/mm ² (Yield strength) Rm = 390 N/mm ² (Breaking strength)
GEARS	Steel UNI 7846	Rs = 980 N/mm ² (Yield strength) Rm = 1270÷1570 N/mm ² (Breaking strength)
SEALS	A 727 Standard Acrylonitrile F 975 Viton FKM	70 Shore, thermal resistance 120°C 80 Shore, thermal resistance 200°C
BACK-UP RINGS	Virgin PTFE Tecnil Q3	

XV-0P CHARACTERISTIC FLOW RATE CURVES

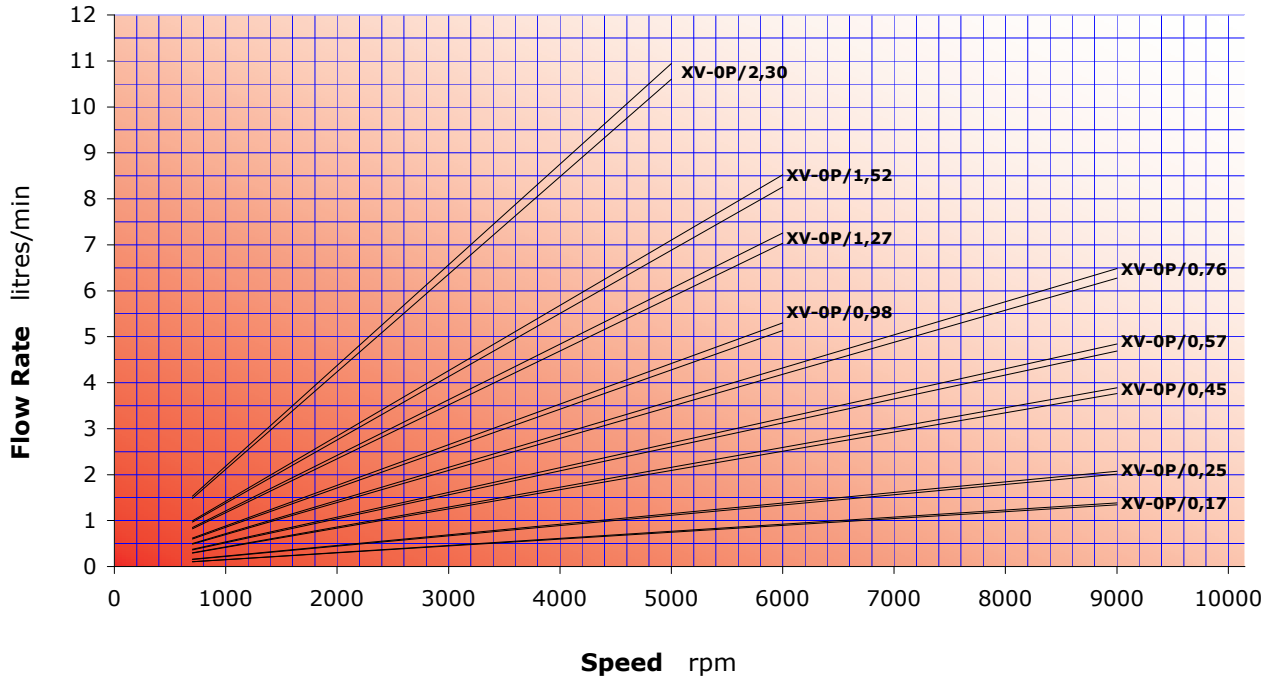

XV-0P MOTOR TORQUE

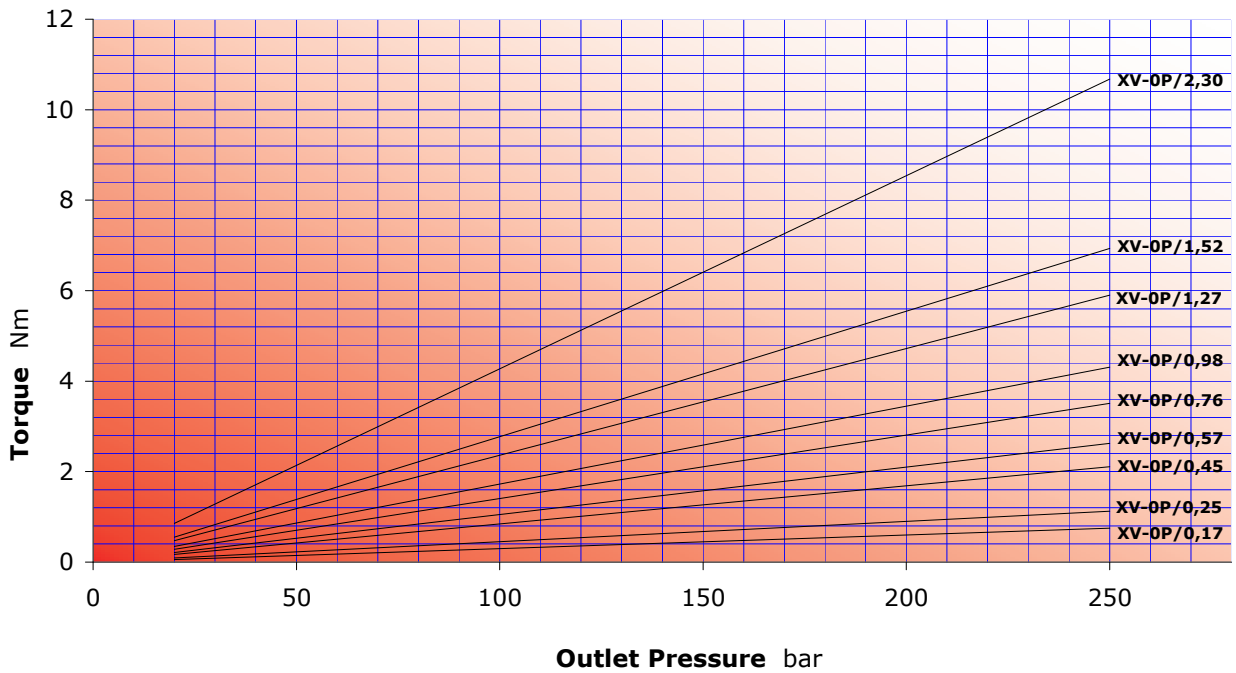

XV0-P with Flange ø22 Std, BH-HY (ref .from XP- 001 to XP-017)

When changing the direction of rotation of the XV-0P pump, it is not necessary to change the flange, as the same one is used.

When disassembling and reassembling the pump, take special care to ensure that seals and back-up rings do not come out of place and that no foreign bodies, such as shavings or dirt in general, get inside the pump.

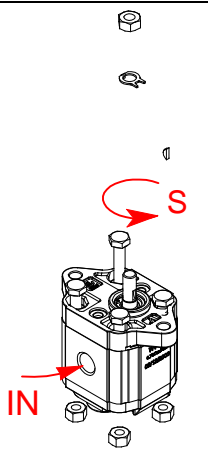
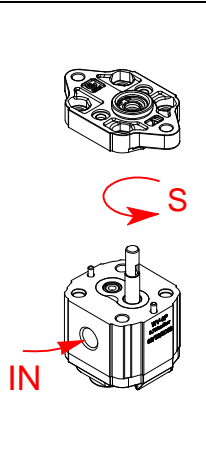
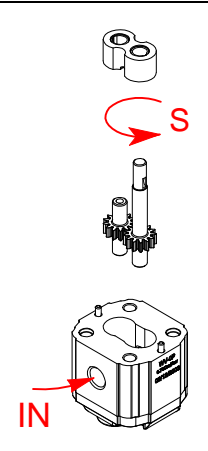
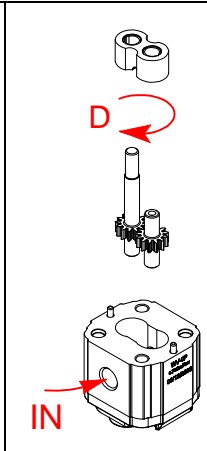
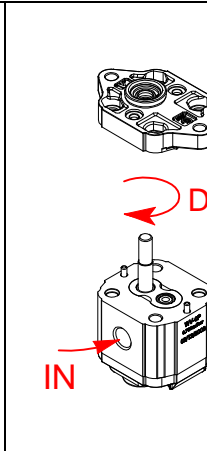
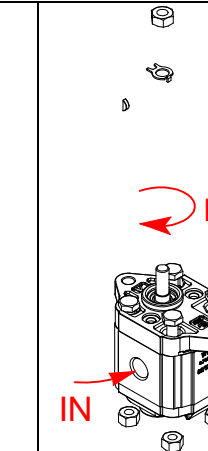
Flange ø22 (ref. from XP- 001 to: XP- 017)					
					
<p>Remove the key, nut and washer from the shaft. Loosen and remove the fastening screws.</p>	<p>Take off the flange.</p>	<p>Take out the gears and upper bush.</p> <p>Warning!! The bush must never be turned.</p>	<p>Invert the positions of the driven and driving shafts.</p> <p>Warning! The body and cover must not be turned. Use the marking on the body as your reference.</p>	<p>Fit the previously removed flange back in place taking care to clean the body-base contact surfaces.</p>	<p>Insert the screws back in place and tighten the nuts with a torque of 11.7 Nm to 13.7 Nm. Check that the shaft turns on completing the operation.</p>
<p>Note: with this rotation change system, the inlets and outlets remain unchanged.</p>					

unidirectional pump - series XV

XV-OP

STANDARD PUMP
ø22 FLANGE - PARALLEL SHAFT

X 0 P 06 02 A B B A

Series	X	series XV
Group	0	group 0
Category	P	unidirectional pump
Displacement	06	0.76
Flange	02	Ø22 right rotation
Shaft	A	CI001 - Parallel ø7 - M7x1 - key thk. 2
Body	IN	inlet - 1/4" GAS
	OUT	outlet - 1/4" GAS
Cover	A	standard

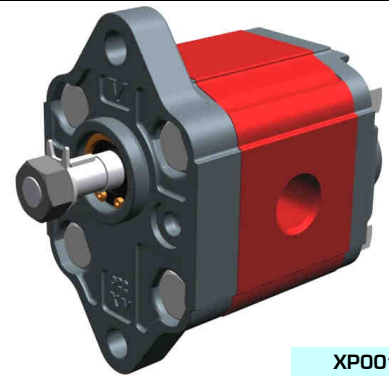

XP001

Technical data table

TYPE	Displacement cm3/rev	Max. Pressure		CODE	
		P1 bar	P3 bar	Left rotation	Right rotation
XV-OP/0.17	0,16	220	260	X 0 P 01 01 A B B A	X 0 P 01 02 A B B A
XV-OP/0.25	0,24	220	260	X 0 P 02 01 A B B A	X 0 P 02 02 A B B A
XV-OP/0.45	0,45	220	280	X 0 P 04 01 A B B A	X 0 P 04 02 A B B A
XV-OP/0.57	0,56	220	280	X 0 P 05 01 A B B A	X 0 P 05 02 A B B A
XV-OP/0.76	0,75	220	280	X 0 P 06 01 A B B A	X 0 P 06 02 A B B A
XV-OP/0.98	0,92	220	280	X 0 P 07 01 A B B A	X 0 P 07 02 A B B A
XV-OP/1.27	1,26	220	280	X 0 P 09 01 A B B A	X 0 P 09 02 A B B A
XV-OP/1.52	1,48	220	280	X 0 P 11 01 A B B A	X 0 P 11 02 A B B A
XV-OP/2.30	2,28	190	210	X 0 P 13 01 A B B A	X 0 P 13 02 A B B A

P1) Max. working pressure - P3) Max. peak pressure

For heavy-duty applications, it is recommended to check the admissible torque of the shaft

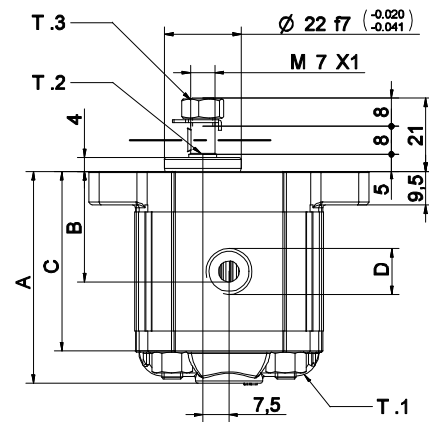
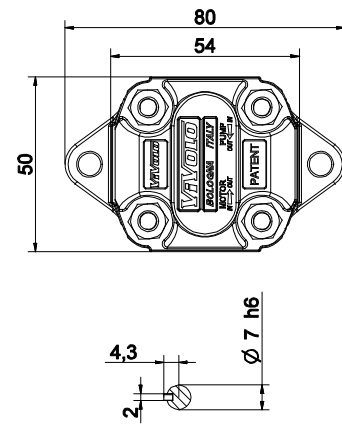

Dimensions table

TYPE	Weight kg	A	B	C	D	D
		mm	mm	mm	IN	OUT
XV-OP/0.17	0,400	55,8	26,2	46,8	1/4" BSPP	1/4" BSPP
XV-OP/0.25	0,410	56,4	26,5	47,4	1/4" BSPP	1/4" BSPP
XV-OP/0.45	0,420	58,0	27,3	49,0	1/4" BSPP	1/4" BSPP
XV-OP/0.57	0,430	59,0	27,8	50,0	1/4" BSPP	1/4" BSPP
XV-OP/0.76	0,440	60,5	28,5	51,5	1/4" BSPP	1/4" BSPP
XV-OP/0.98	0,460	62,0	29,3	53,0	1/4" BSPP	1/4" BSPP
XV-OP/1.27	0,480	64,5	30,5	55,5	1/4" BSPP	1/4" BSPP
XV-OP/1.52	0,500	66,5	31,5	57,5	1/4" BSPP	1/4" BSPP
XV-OP/2.30	0,560	72,5	34,5	63,5	1/4" BSPP	1/4" BSPP

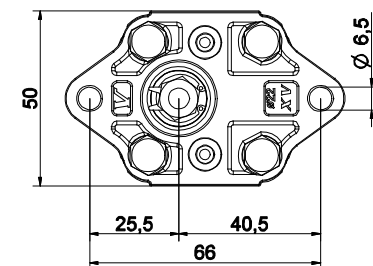

07/12/04 XVOP0602BBA.rtf

T.1 = 11.7÷13.7 [Nm] - screw tightening torque M6

T.3 = 11.5 [Nm] - torque wrench setting 11

T.2 = 2.1 [Nm] - admissible shaft torque (N.B. When choosing a shaft, always check the admissible torque).

Table of variations

XV-OP

Standard ø22 FLANGE

Standard ø22 FLANGE				Shaft				Cover			
Left rotation		Right rotation						Left rotation		Right rotation	
	01		02	CI001 - Parallel T.2 = 2.1 [Nm]	A	CF001 - Milled shank T.2 = 9.2 [Nm]	B				A
	03		04	CF005 - Milled shank T.2 = 8.4 [Nm]	F	CO001 - Tapered T.2 = 21.9 [Nm]	E				B
	05		06								C
	07		08								D

Displacement	
TYPE	CODE
XV-0P/0.17	01
XV-0P/0.25	02
XV-0P/0.45	04
XV-0P/0.57	05
XV-0P/0.76	06
XV-0P/0.98	07
XV-0P/1.27	09
XV-0P/1.52	11
XV-0P/2.30	13

Standard bodies				
Displacement cm3/rev	Standard threads			
	0,17	B - B	Z - B	Z - Z
0,25	B - B	Z - B	Z - Z	
0,45	B - B	Z - B	Z - Z	
0,57	B - B	Z - B	Z - Z	
0,76	B - B	Z - B	Z - Z	
0,98	B - B	Z - B	Z - Z	
1,27	B - B	Z - B	Z - Z	
1,52	B - B	Z - B	Z - Z	
2,30	B - B	Z - B	Z - Z	

Table showing standard flange and thread combinations available in stock

			N
Internal drainage			
			O
External drainage			

Body (threads/flanges)													
	A		B		C		D		E		F		G
	H		I	Closed Body		Z							

unidirectional pump - series XV

XV-OP

BH TYPE PUMP

ø22 BODY-SHAPED FLANGE - MILLED SHANK

X 0 P 06 12 B B B A

Series	X	series XV
Group	0	group 0
Category	P	unidirectional pump
Displacement	06	0.76
Flange	12	Ø22 BH right rotation
Shaft	B	CF001 - Milled shank ø7 - thk.5
Body	IN	inlet - 1/4" GAS
	OUT	outlet - 1/4" GAS
Cover	A	standard



XP012

Technical data table						
TYPE	Displacement cm3/rev	Max. Pressure		CODE		
		P1 bar	P3 bar	Left rotation	Right rotation	
XV-OP/0.17	0,16	220	260	X 0 P 01 11 B B B A	X 0 P 01 12 B B B A	
XV-OP/0.25	0,24	220	260	X 0 P 02 11 B B B A	X 0 P 02 12 B B B A	
XV-OP/0.45	0,45	220	280	X 0 P 04 11 B B B A	X 0 P 04 12 B B B A	
XV-OP/0.57	0,56	220	280	X 0 P 05 11 B B B A	X 0 P 05 12 B B B A	
XV-OP/0.76	0,75	220	280	X 0 P 06 11 B B B A	X 0 P 06 12 B B B A	
XV-OP/0.98	0,92	220	280	X 0 P 07 11 B B B A	X 0 P 07 12 B B B A	
XV-OP/1.27	1,26	220	280	X 0 P 09 11 B B B A	X 0 P 09 12 B B B A	
XV-OP/1.52	1,48	220	280	X 0 P 11 11 B B B A	X 0 P 11 12 B B B A	
XV-OP/2.30	2,28	190	210	X 0 P 13 11 B B B A	X 0 P 13 12 B B B A	

P1) Max. working pressure - P3) Max. peak pressure

For heavy-duty applications, it is recommended to check the admissible torque of the shaft

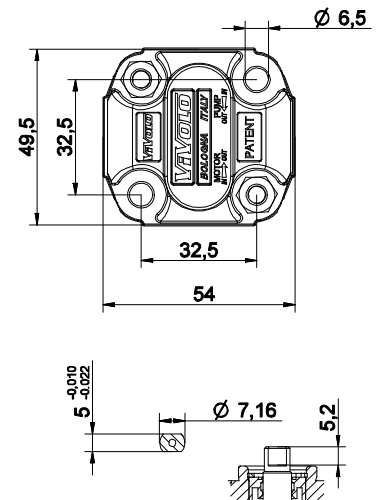

Dimensions table						
TYPE	Weight kg	A	B	C	D	D
		mm	mm	mm	IN	OUT
XV-OP/0.17	0,400	55,8	26,2	46,8	1/4" BSPP	1/4" BSPP
XV-OP/0.25	0,410	56,4	26,5	47,4	1/4" BSPP	1/4" BSPP
XV-OP/0.45	0,420	58,0	27,3	49,0	1/4" BSPP	1/4" BSPP
XV-OP/0.57	0,430	59,0	27,8	50,0	1/4" BSPP	1/4" BSPP
XV-OP/0.76	0,440	60,5	28,5	51,5	1/4" BSPP	1/4" BSPP
XV-OP/0.98	0,460	62,0	29,3	53,0	1/4" BSPP	1/4" BSPP
XV-OP/1.27	0,480	64,5	30,5	55,5	1/4" BSPP	1/4" BSPP
XV-OP/1.52	0,500	66,5	31,5	57,5	1/4" BSPP	1/4" BSPP
XV-OP/2.30	0,560	72,5	34,5	63,5	1/4" BSPP	1/4" BSPP

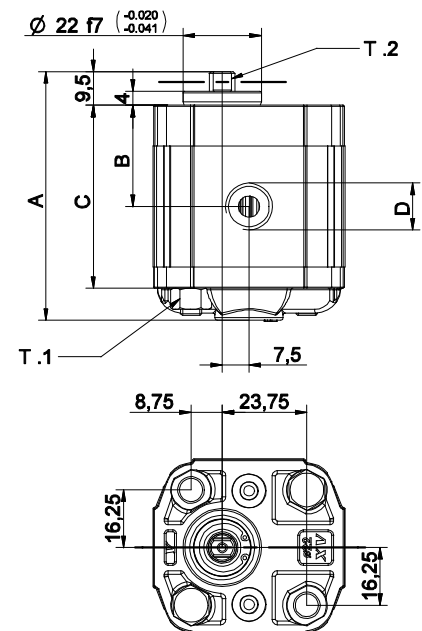

T.1 = 11.7÷13.7 [Nm] - screw tightening torque M6

T.2 = 9.2 [Nm] - admissible shaft torque (N.B. When choosing a shaft, always check the admissible torque).

07/12/04 XP0612BBBA.dff

Table of variations

XV-OP

ø22 "BH" Body-Shaped FLANGE

ø22 "BH" Body-Shaped FLANGE				Shaft				Cover			
Left rotation		Right rotation						Left rotation		Right rotation	
	11		12	CI001 - Parallel T.2 = 2.1 [Nm]	A	CF001 - Milled shank T.2 = 9.2 [Nm]	B				A
	13		14	CF005 - Milled shank T.2 = 8.4 [Nm]	F	CO001 - Tapered T.2 = 21.9 [Nm]	E				B
	15		16								C
	17		18								D

Displacement	
TYPE	CODE
XV-0P/0.17	01
XV-0P/0.25	02
XV-0P/0.45	04
XV-0P/0.57	05
XV-0P/0.76	06
XV-0P/0.98	07
XV-0P/1.27	09
XV-0P/1.52	11
XV-0P/2.30	13

Displacement cm ³ /rev	Standard bodies		
	Standard threads		
0,17	B - B	Z - B	Z - Z
0,25	B - B	Z - B	Z - Z
0,45	B - B	Z - B	Z - Z
0,57	B - B	Z - B	Z - Z
0,76	B - B	Z - B	Z - Z
0,98	B - B	Z - B	Z - Z
1,27	B - B	Z - B	Z - Z
1,52	B - B	Z - B	Z - Z
2,30	B - B	Z - B	Z - Z

Table showing standard flange and thread combinations available in stock

			N
Internal drainage			
			O
External drainage			

Body (threads/flanges)													
	A		B		C		D		E		F		G
	H		I	Closed Body		Z							

unidirectional pump - series XV

XV-OP

HY TYPE PUMP

Ø22 BODY-SHAPED FLANGE - MILLED SHANK

X 0 P 06 22 B B B A

Series	X	series XV
Group	0	group 0
Category	P	unidirectional pump
Displacement	06	0.76
Flange	22	Ø22 HY right rotation
Shaft	B	CF001 - Milled shank ø7 - thk.5
Body	IN	inlet - 1/4" GAS
	OUT	outlet - 1/4" GAS
Cover	A	standard



XP017

Technical data table

TYPE	Displacement cm3/rev	Max. Pressure		CODE	
		P1 bar	P3 bar	Left rotation	Right rotation
XV-OP/0.17	0,16	220	260	X 0 P 01 21 B B B A	X 0 P 01 22 B B B A
XV-OP/0.25	0,24	220	260	X 0 P 02 21 B B B A	X 0 P 02 22 B B B A
XV-OP/0.45	0,45	220	280	X 0 P 04 21 B B B A	X 0 P 04 22 B B B A
XV-OP/0.57	0,56	220	280	X 0 P 05 21 B B B A	X 0 P 05 22 B B B A
XV-OP/0.76	0,75	220	280	X 0 P 06 21 B B B A	X 0 P 06 22 B B B A
XV-OP/0.98	0,92	220	280	X 0 P 07 21 B B B A	X 0 P 07 22 B B B A
XV-OP/1.27	1,26	220	280	X 0 P 09 21 B B B A	X 0 P 09 22 B B B A
XV-OP/1.52	1,48	220	280	X 0 P 11 21 B B B A	X 0 P 11 22 B B B A
XV-OP/2.30	2,28	190	210	X 0 P 13 21 B B B A	X 0 P 13 22 B B B A

P1) Max. working pressure - P3) Max. peak pressure

For heavy-duty applications, it is recommended to check the admissible torque of the shaft

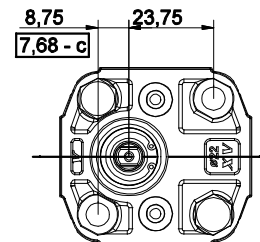
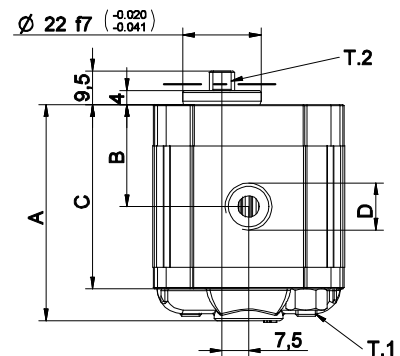
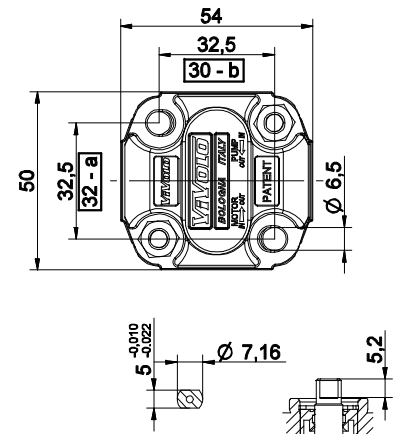

TYPE	Weight kg	Dimensions table				
		A mm	B mm	C mm	D IN	D OUT
XV-OP/0.17	0,400	55,8	26,2	46,8	1/4" BSPP	1/4" BSPP
XV-OP/0.25	0,410	56,4	26,5	47,4	1/4" BSPP	1/4" BSPP
XV-OP/0.45	0,420	58,0	27,3	49,0	1/4" BSPP	1/4" BSPP
XV-OP/0.57	0,430	59,0	27,8	50,0	1/4" BSPP	1/4" BSPP
XV-OP/0.76	0,440	60,5	28,5	51,5	1/4" BSPP	1/4" BSPP
XV-OP/0.98	0,460	62,0	29,3	53,0	1/4" BSPP	1/4" BSPP
XV-OP/1.27	0,480	64,5	30,5	55,5	1/4" BSPP	1/4" BSPP
XV-OP/1.52	0,500	66,5	31,5	57,5	1/4" BSPP	1/4" BSPP
XV-OP/2.30	0,560	72,5	34,5	63,5	1/4" BSPP	1/4" BSPP

T.1 = 11.7÷13.7 [Nm] - screw tightening torque M6

T.2 = 9.2 [Nm] - admissible shaft torque (N.B. When choosing a shaft, always check the admissible torque).

NOTE: This type of pump is also interchangeable

with distance between centres of fastening in M5 (see dim. a, b, c).

07/12/04 XP062288A.dft

Table of variations

XV-OP

ø22 "HY" Body-Shaped FLANGE

ø22 "HY" Body-Shaped FLANGE				Shaft				Cover			
Left rotation		Right rotation						Left rotation		Right rotation	
	21		22	CI001 - Parallel T.2 = 2.1 [Nm]	A	CF001 - Milled shank T.2 = 9.2 [Nm]	B			A	
	23		24	CF005 - Milled shank T.2 = 8.4 [Nm]	F	CO001 - Tapered T.2 = 21.9 [Nm]	E			B	
	25		26							C	
	27		28							D	

Displacement	
TYPE	CODE
XV-0P/0.17	01
XV-0P/0.25	02
XV-0P/0.45	04
XV-0P/0.57	05
XV-0P/0.76	06
XV-0P/0.98	07
XV-0P/1.27	09
XV-0P/1.52	11
XV-0P/2.30	13

Displacement cm ³ /rev	Standard bodies		
	Standard threads		
0,17	B - B	Z - B	Z - Z
0,25	B - B	Z - B	Z - Z
0,45	B - B	Z - B	Z - Z
0,57	B - B	Z - B	Z - Z
0,76	B - B	Z - B	Z - Z
0,98	B - B	Z - B	Z - Z
1,27	B - B	Z - B	Z - Z
1,52	B - B	Z - B	Z - Z
2,30	B - B	Z - B	Z - Z

Table showing standard flange and thread combinations available in stock

		N	
Internal drainage			
		O	
External drainage			

Body (threads/flanges)													
	A		B		C		D		E		F		G
	H		I	Closed Body		Z							

DOUBLE SHAFT - Variant VA

All versions may be supplied with a double shaft using all types of shafts and flanges
As per catalogue

Example of order code

Standard -----X0P0602ABBA
With double shaft -----X0P0602ABBA **VA**

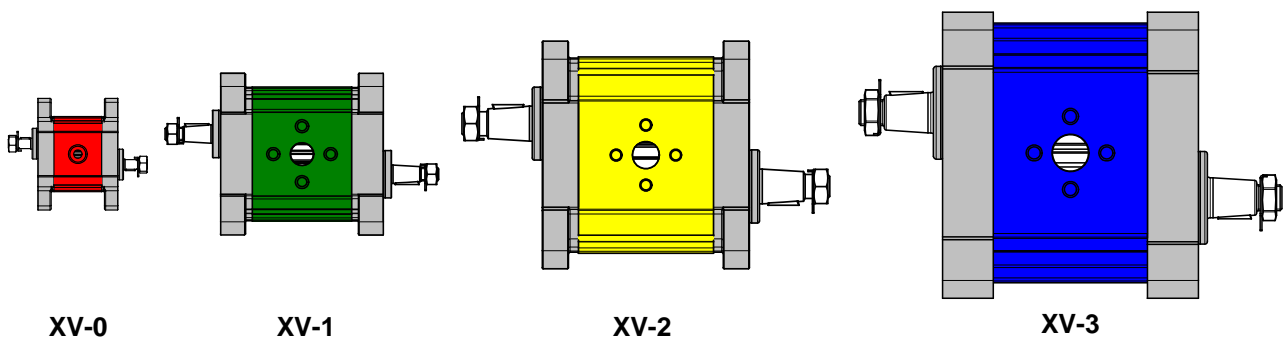

SEALS made of FKM (viton) variant VITON

All versions may be supplied with **FKM (viton)** seals

Example of order code

Standard-----X0P0602ABBA
With FKM (viton) seals -----X0P0602ABBA **VITON**

O-RINGS

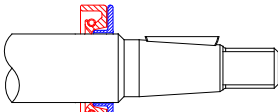
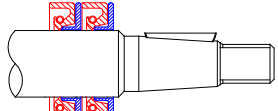
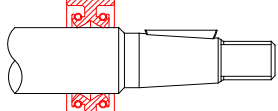
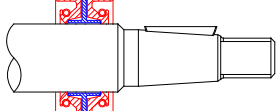
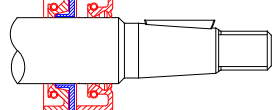
Variant VDC		Oil seal with backup washer (standard for motors)
Variant VDCX		Double oil seal with double backup washer
Variant VDB		DUPLEX oil seal
Variant VDBX		Double opposed oil seal with backup washer
Variant VDCO		Motor Oil Seal with backup washer + Standard Oil Seal

Example of order code

Standard-----X1P0602FIIA
With oil seal and retaining washer -----X1P0602FIIA **VDC**

Pressure-relief valve VM25 for XV0 series

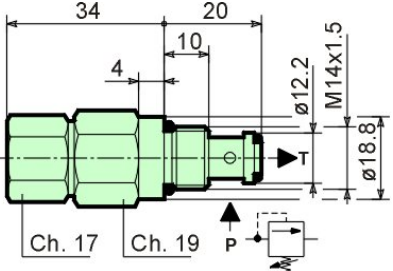
	Technical specifications	
	Capacity	25 l/min
	Max pressure in P	315 bars
	Max pressure in T	315 bars
	Setting range of spring Type 01	20-140 bars
	Setting range of spring Type 02	70-315 bars
	Required filtration	10-15 µm
	Oil viscosity range	2.8-350 cSt
	Recommended oil temperature	-20 + 80 °C
	Seal material	Buna N
	Weight	0.110 kg
	Pressures with flow of 1 l/min: opening value in relation to setting	95%
	Closing value in relation to setting	75%
	Hydraulic oil	HM, HV ISO 6074

Pressure-relief valve VM50 for XV1 and XV2 series

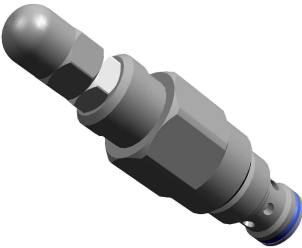
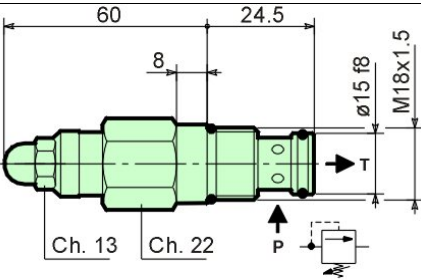
	Technical specifications	
	Capacity	50/min
	Max pressure in P	350 bars
	Max pressure in T	350 bars
	Setting range of spring Type 01	10-105 bars
	Setting range of spring Type 02	70-210 bars
	Setting range of spring Type 03	140-350 bars
	Required filtration	10-15 µm
	Oil viscosity range	2.8-350 cSt
	Recommended oil temperature	-20 + 80 °C
	Seal material	Buna N
	Weight	0.125 kg
	Pressures with flow of 1 l/min: opening value in relation to setting	95%
	Closing value in relation to setting	75%
	Hydraulic oil	HM, HV ISO 6074

Standard test settings

TYPE	Pressure (bars)	Capacity (l/min)	Pressure increase (bars x turn of screw)
1 (10-105 bars)	50	5	15
2 (70-210 bars)	130	5	32
3 (140-350 bars)	200	5	67

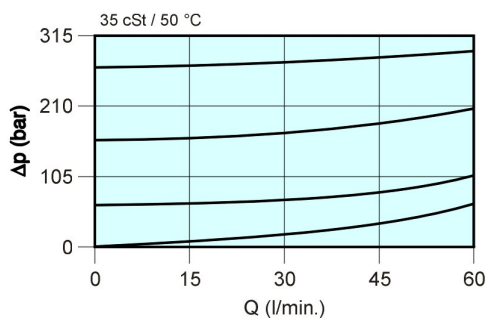

Performance of VM25 and VM50 valves

Δp = Pressure drop in bars

Q = Capacity in litres per minute

90° STEEL ELBOWS

Code	Type	A	B	C	D	E	F	G	OR	V	weigth
									O ring	Screw	
8KRG001	RG 26/12-3/8"BSP	3/8"	26	5,5	12	18	9,5	27	ø14,00x1,78	M5x18	0,13
8KRG002	RG 26/12-1/2"BSP	1/2"	26	5,5	12	18	9,5	27	ø14,00x1,78	M5x18	0,12
8KRG003	RG 30/13,5 -3/8"BSP	3/8"	30	6,5	13,5	18	9,5	27	ø15,88x2,62	M6x20	0,17
8KRG004	RG 30/13,5 -1/2"BSP	1/2"	30	6,5	13,5	18	9,5	27	ø15,88x2,62	M6x20	0,16
8KRG005	RG 40/20-1/2"BSP	1/2"	40	8,5	20	21	10,5	38	ø23,81x2,62	M8x25	0,36
8KRG006	RG 40/20-3/4"BSP	3/4"	40	8,5	20	21	10,5	38	ø23,81x2,62	M8x25	0,32
8KRG007	RG 40/23-3/4"BSP	3/4"	40	8,5	23,5	21	10,5	38	ø25,12x1,78	M8x25	0,29
8KRG008	RG 51/27-1"BSP	1"	51	10,5	27	27	13,5	47	ø31,42x2,62	M10x30	0,7
8KRG009	RG 51/27-3/4" BSP	3/4"	51	10,5	27	27	13,5	47	ø31,42x2,62	M10x30	0,7
8KRG011	RG 56/34-3/4" BSP	3/4"	56	10,5	34	27	13,5	47	ø37,77x2,62	M10x30	0,72
8KRG012	RG 62/36-1"1/4 BSP	1"1/4	62	10,5	36	36	19	56	ø41,28x3,53	M10x30	0,94
8KRG015	RG 62/36-1"1/4 BSP M12	1"1/4	62	12,5	36	36	19	56	ø41,28x3,53	M12x35	0,94
8KRG013	RG 72,5/45-1"1/2 BSP	1"1/2	72,5	12,5	45	38	16	58	ø49,20x3,53	M12x35	1,23
8KRG014	RG 92/65-2" BSP	2	92	12,5	65	50	21	75	ø69,85x3,53	M12x40	1,65

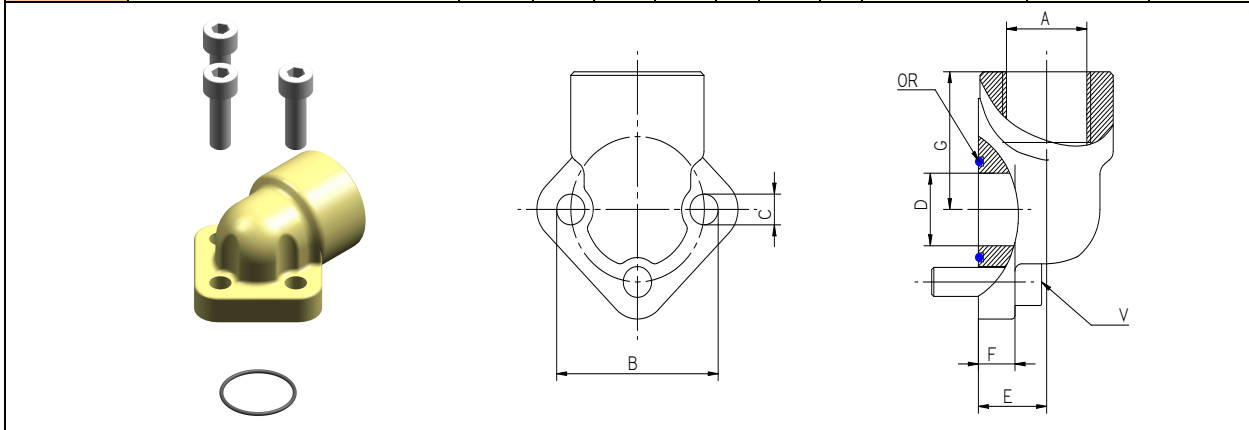

STRAIGHT STEEL UNIONS

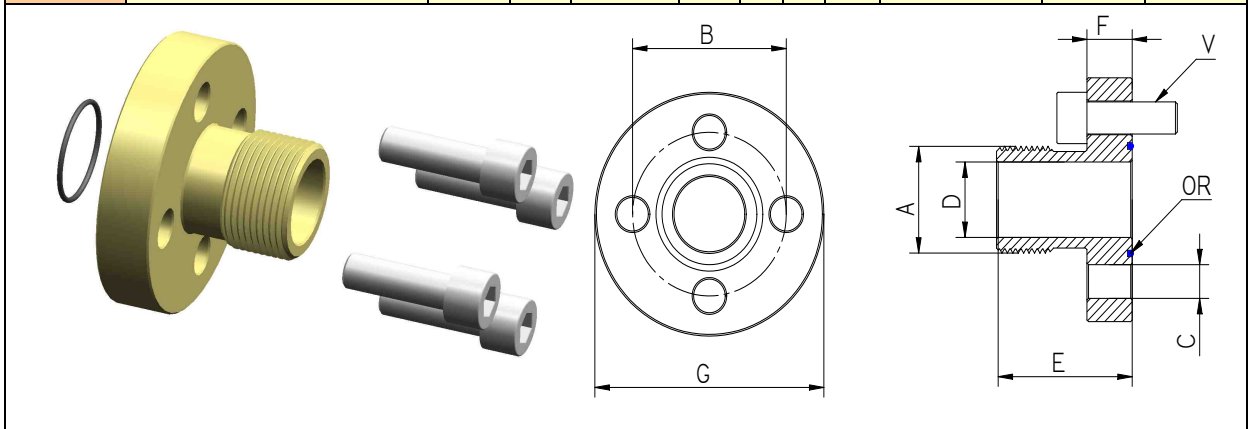
Code	Type	A	B	C	D	E	F	G	OR	V	Weigth
									O ring	Screw	
8KRD001	RD 26/12-3/8"BSP	3/8"	26	5,5	12	32	10	39	ø14,00x1,78	M5x18	0,11
8KRD002	RD 30/13,5-1/2"BSP	1/2"	30	6,5	13,5	40	10	44	ø15,88x2,62	M6x20	0,14
8KRD005	RD 40/20-3/4"BSP	3/4"	40	8,5	20	42	12	51	ø23,81x2,62	M8x25	0,3
8KRD006	RD 40/23,5-3/4"BSP	3/4"	40	8,5	23,5	42	12	51	ø25,12x1,78	M8x25	0,29
8KRD007	RD 51/27-1"BSP	1"	51	10,5	27	43	12	68	ø31,42x2,62	M10x25	0,46
8KRD008	RD 56/34-1"1/4 BSP	1" 1/4	56	10,5	34	53	12	73	ø37,77x2,62	M10x25	0,68
8KRD009	RD 62/36-1"1/4 BSP	1" 1/4	62	10,5	36	47	13	78	ø41,28x3,53	M10x25	0,9
8KRD010	RD 72,5/45-1"1/2 BSP	1" 1/2	72,5	12,5	45	49	14	89	ø49,20x3,53	M12x30	1,05
8KRD011	RD 92/65-2"1/2 BSP	2" 1/2	92	12,5	65	60	18	114	ø69,85x3,53	M12x40	1,15

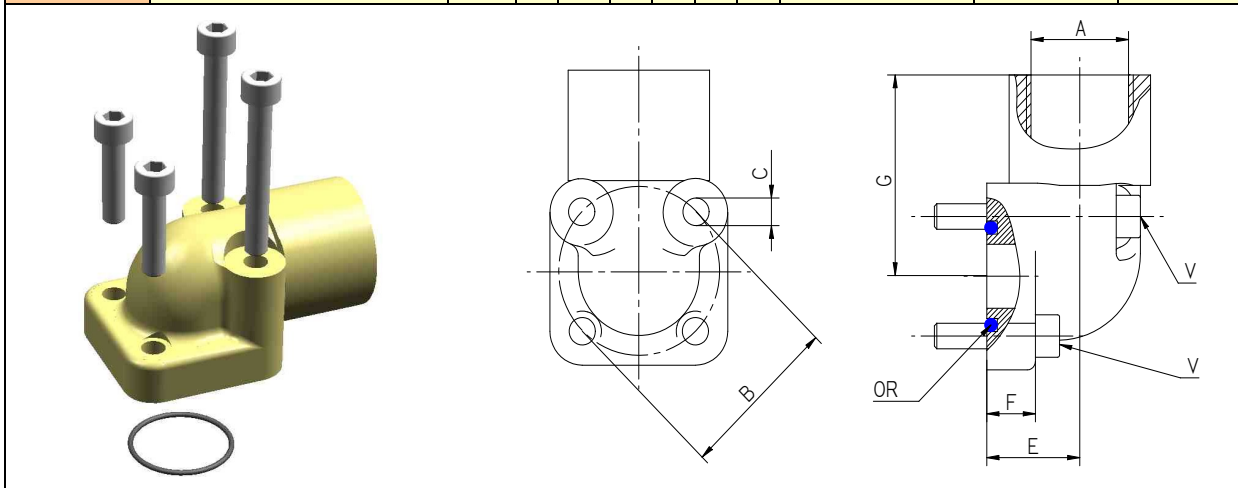

SQUARED STEEL ELBOWS

Code	Type	A	B	C	D	E	F	G	OR	V	Weight
									O ring	Screw	
8KRQ001	RQ 30/12-3/8"BSP	3/8"	30	6,5	12	19	11	41	ø15,88x2,61	Nº2 M6x20 Nº2 M6x35	0,29
8KRQ002	RQ 30/12-1/2"BSP	1/2"	30	6,5	12	19	11	41	ø15,88x2,62	Nº2 M6x20 Nº2 M6x35	0,29
8KRQ003	RQ 35/15 -3/8"BSP	3/8"	35	6,5	15	18	11	40	ø18,72x2,62	Nº2 M6x20 Nº2 M6x35	0,34
8KRQ004	RQ 35/15 -1/2"BSP	1/2"	35	6,5	15	18	11	40	ø18,72x2,62	Nº2 M6x20 Nº2 M6x35	0,34
8KRQ005	RQ 40/20-1/2"BSP	1/2"	40	6,5	20	24	10	45	ø22,22x2,62	Nº2 M6x25 Nº2 M6x45	0,4
8KRQ006	RQ 40/20-3/4"BSP	3/4"	40	6,5	20	24	10	45	ø22,22x2,62	Nº2 M6x25 Nº2 M6x45	0,4
8KRQ007	RQ 55/25-3/4"BSP	3/4"	55	8,5	25	35	13	54	ø29,75x3,53	Nº2 M8x25 Nº2 M8x60	0,45
8KRQ008	RQ 55/25-1" BSP	1"	55	8,5	25	35	13	54	ø29,75x3,53	Nº2 M8x25 Nº2 M8x60	0,45

STRAIGHT STEEL UNIONS

Code	Type	A	B	C	D	E	F	G	OR	V	Weight
									O ring	Screw	
8KRD003	RD 35/15 (BH)-1/2"BSP	1/2"	35	6,5	14	35	10	40	ø18,72x2,62	M6x20	0,15
8KRD004	RD 40/20 (BH)-3/4"BSP	3/4"	40	6,5	17	35	10	40	ø22,22x2,62	M6x20	0,17

